

The coolest cargo makes the hottest headlines

LNG Market – Update

Jakub Walenkiewicz

Principal Market Analyst

2017

LNG Carriers - Av. spot earnings (k\$/day)

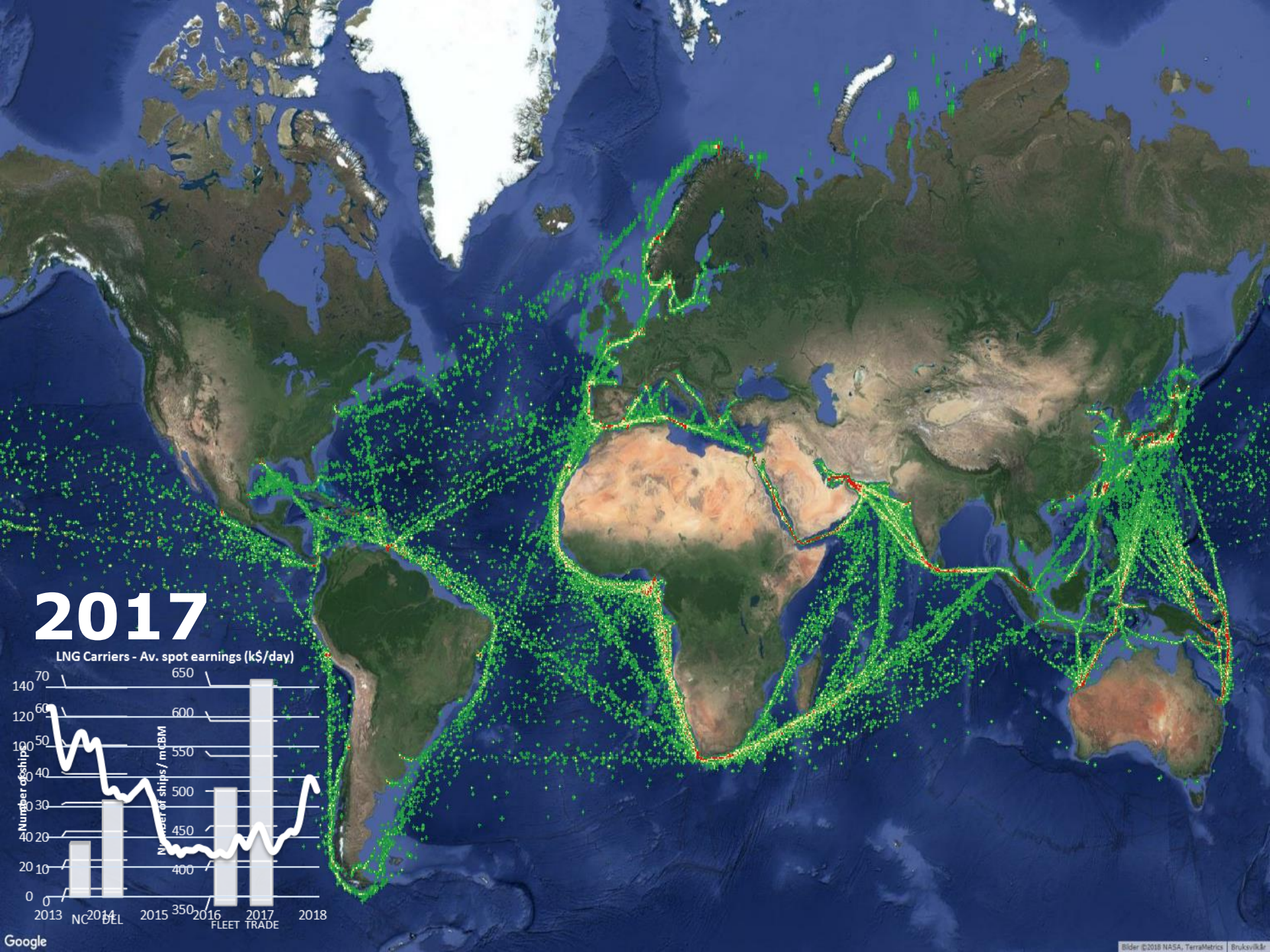
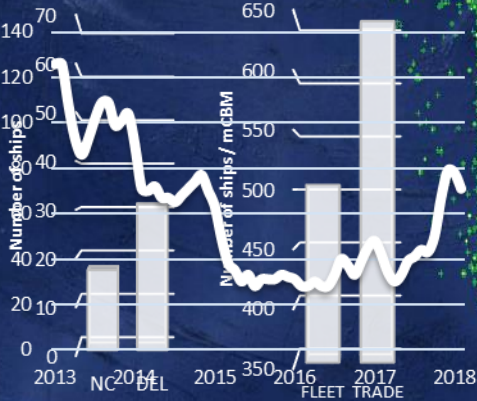

NEW LNG SUPPLY BY PROJECT START DATE

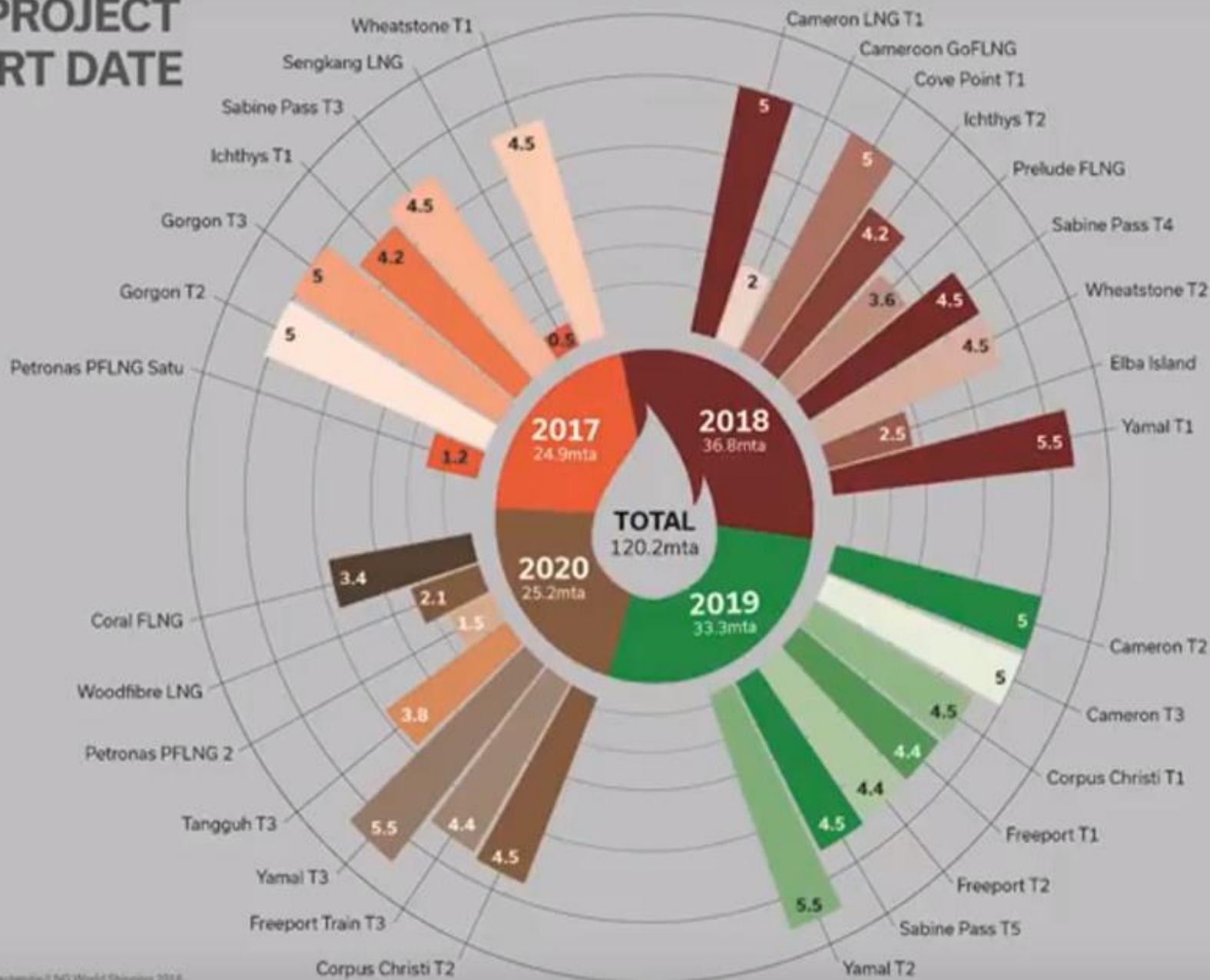

Currently there are 24 FSRUs in operation, mainly located in Middle East & North Africa and South America

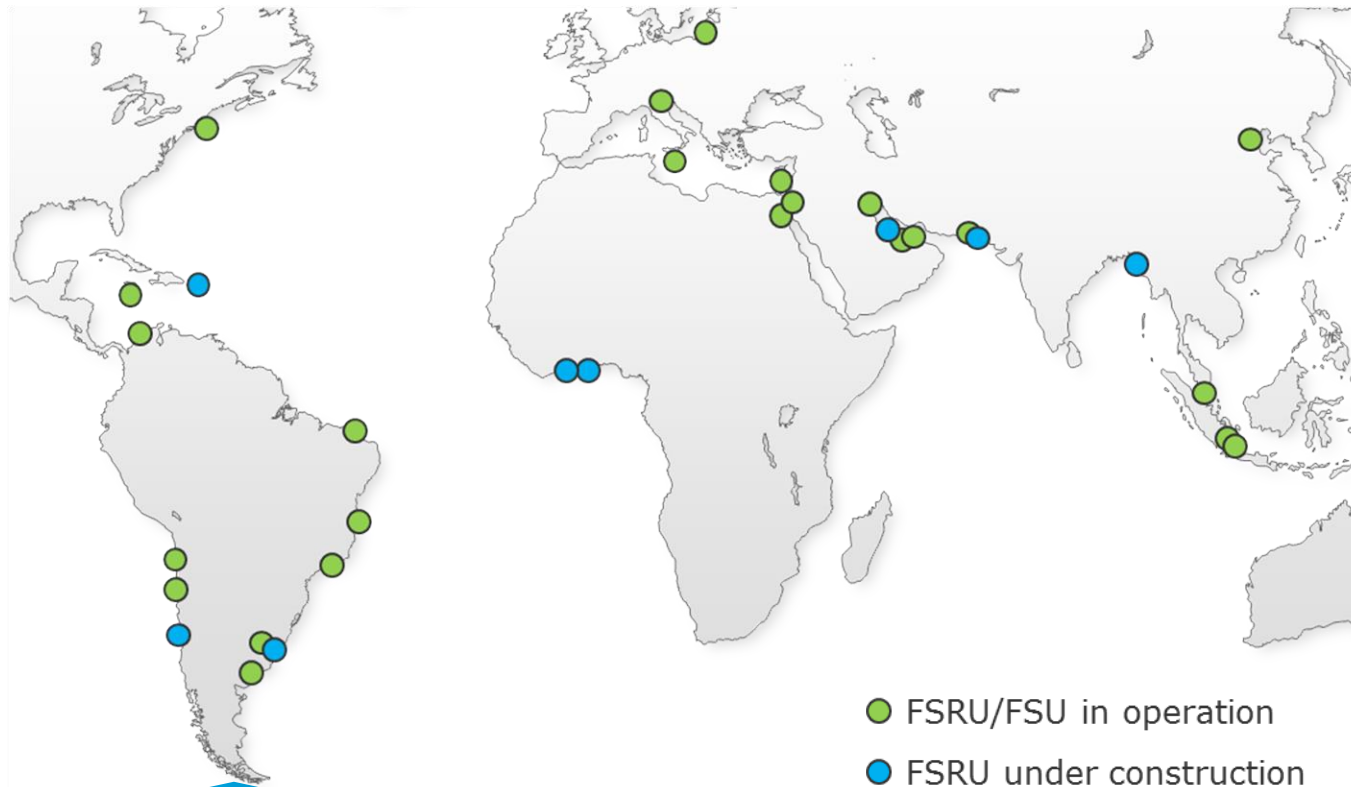

FSRUs in operation:

24

FSRU orderbook:

15 +options

Potential next 5 years:

30-50

KEY COMPANIES

EXMAR/EXCELERATE

10 in operation

1 on order

HÖEGH

7 in operation

3 on order

GOLAR LNG

7 in operation

2 on order

BW GAS

2 in operation

1 on order

Source: AIS data, Feb. 2017

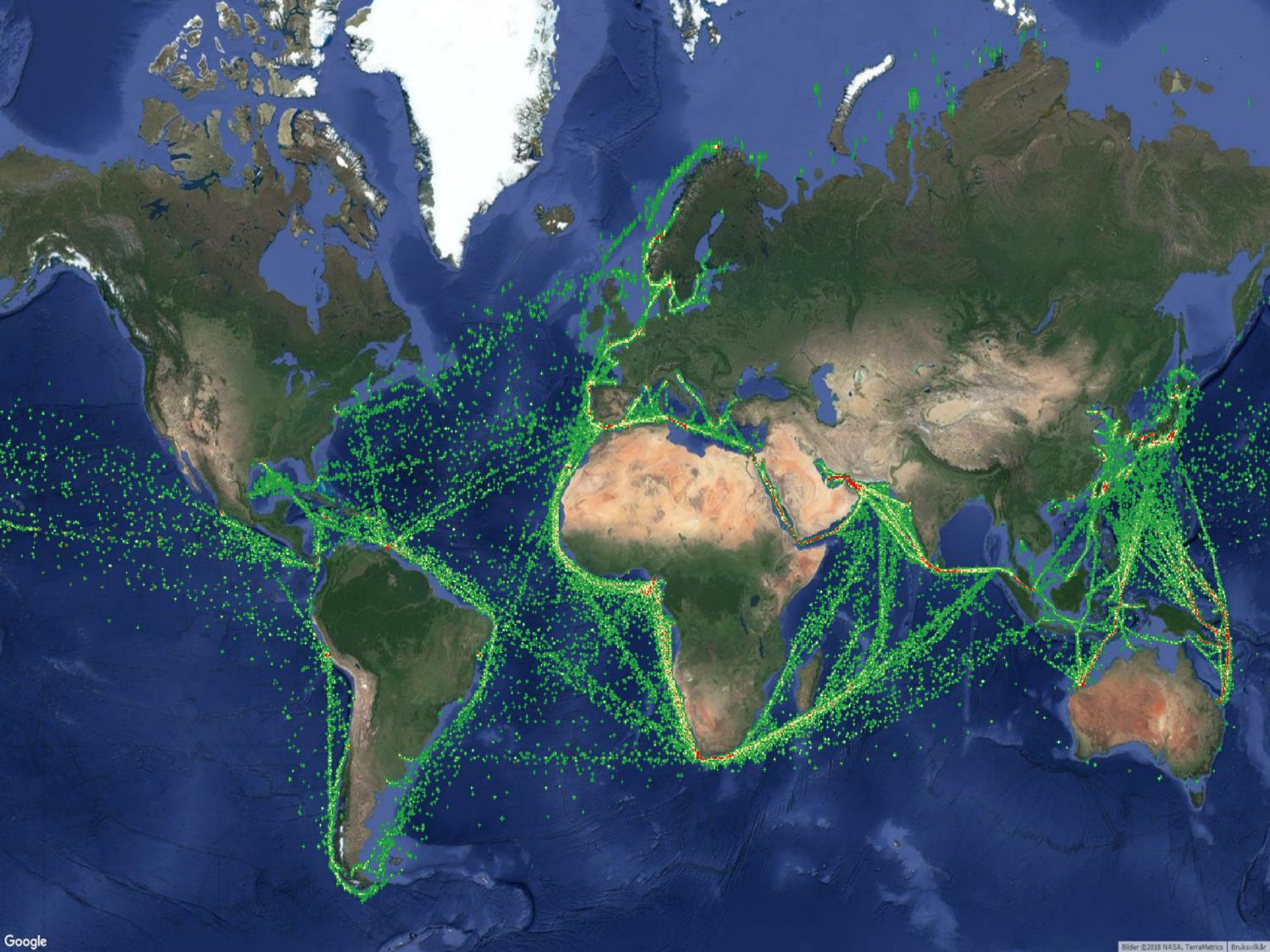



FREEDOM

IMO Classification of cargo containment systems - examples

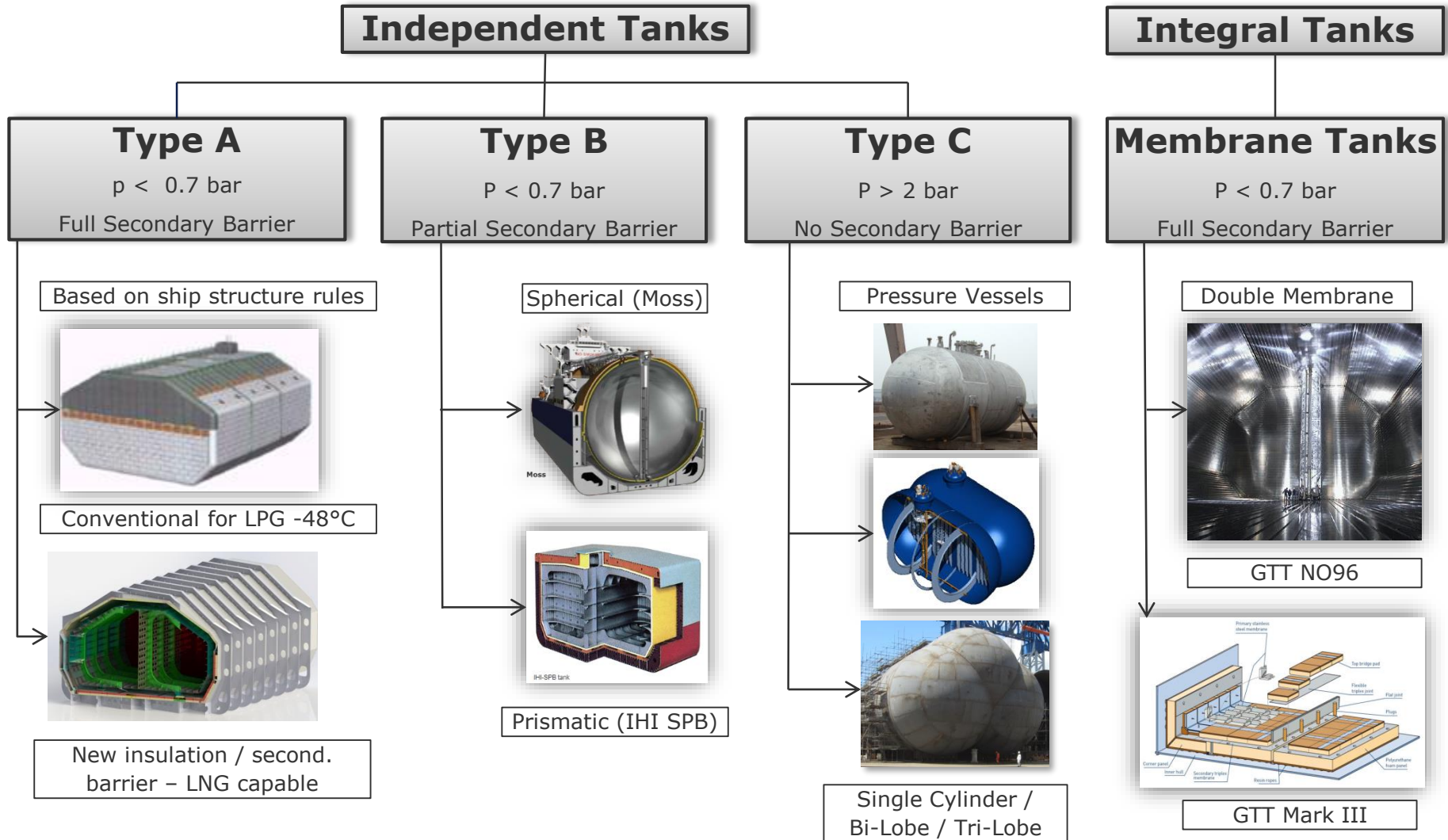

Fleet and Order book by containment system

LNG Fleet and Order book by CCS

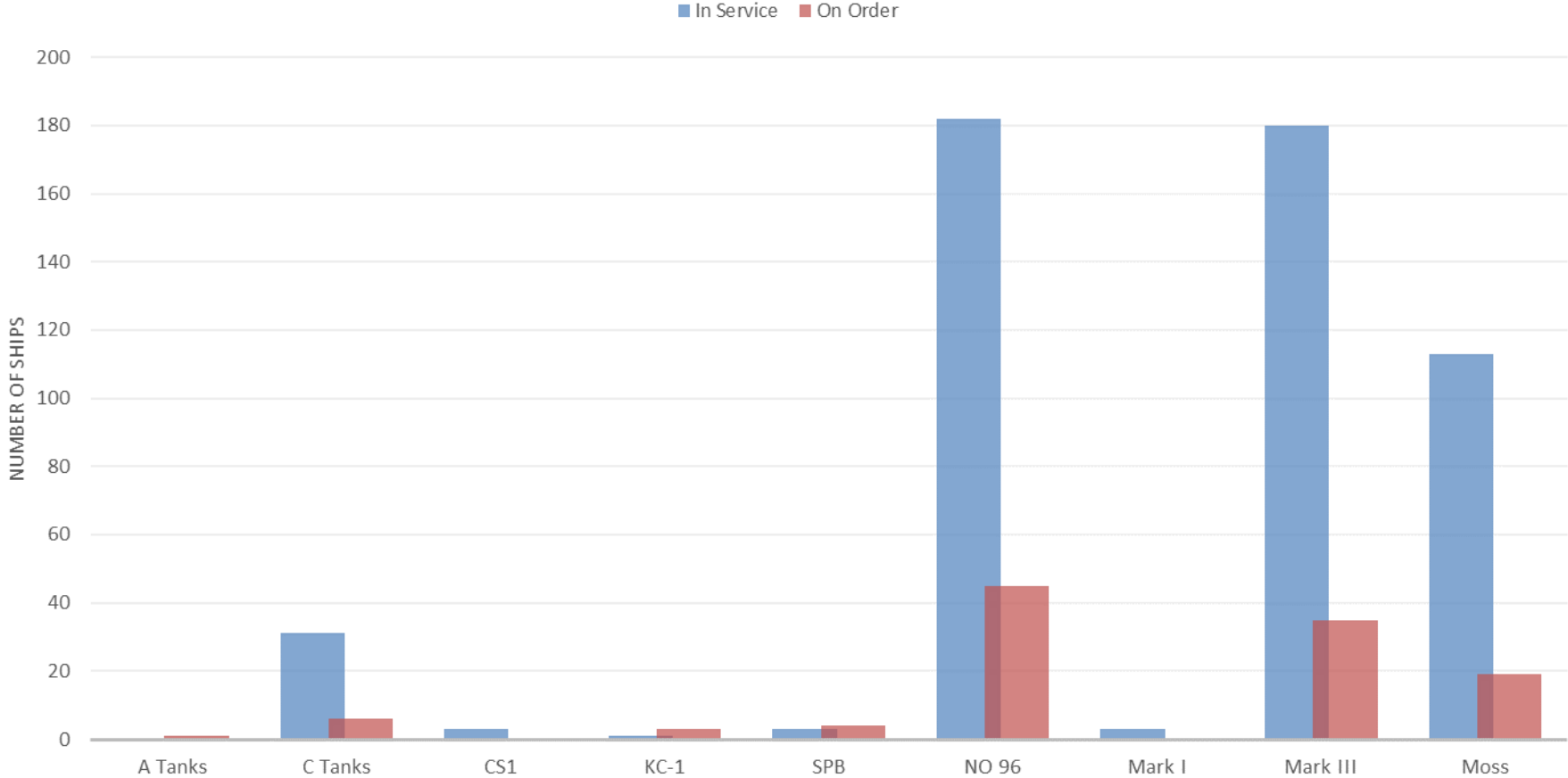

Year of built vs size

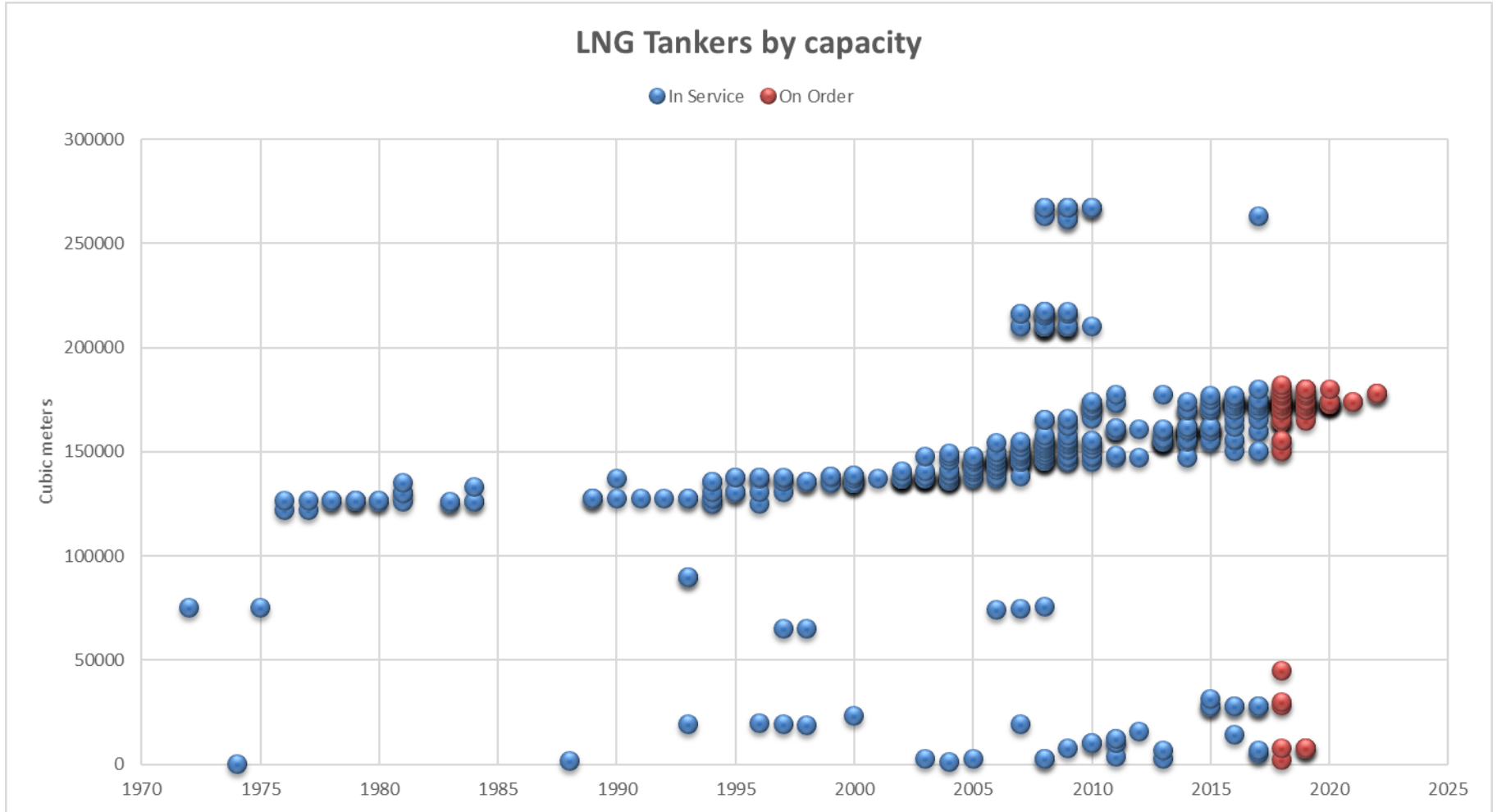

LNG Carriers – age profile

LNG Fleet by Age and CCS

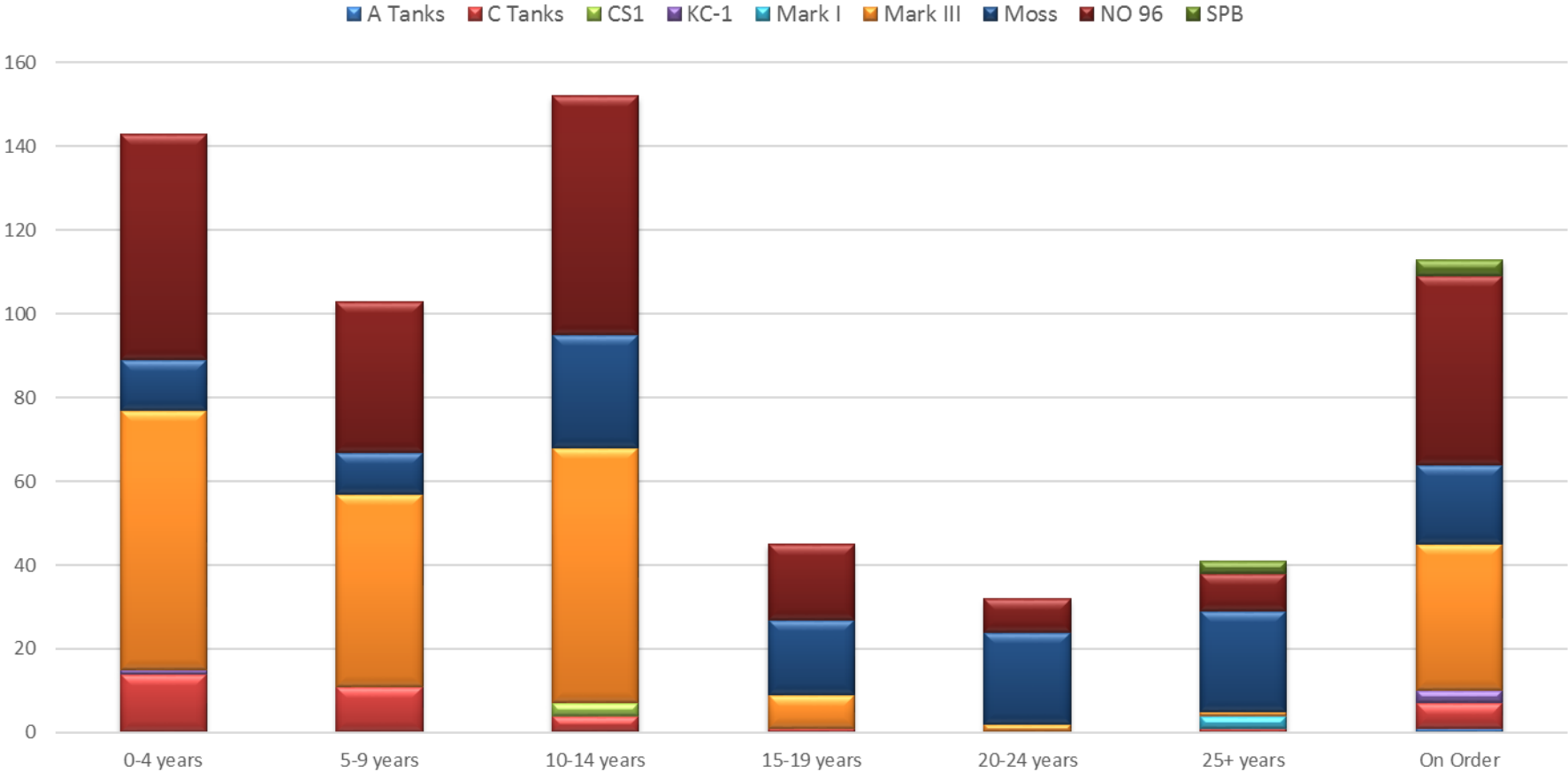

Fleet and Orderbook by size

LNG FLEET IN SERVICE

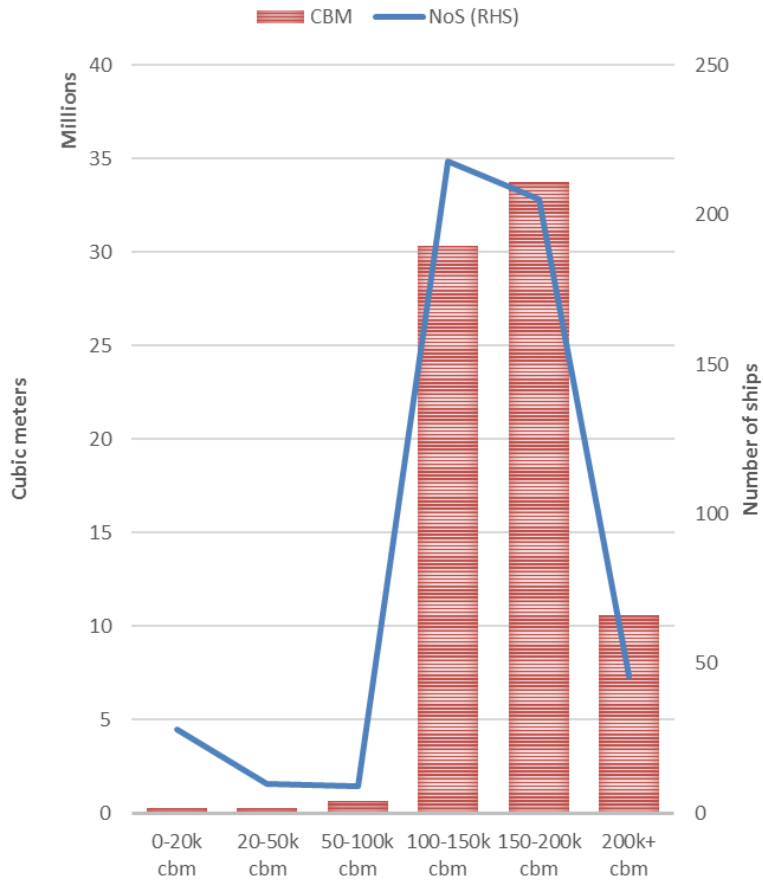

LNG FLEET ON ORDER

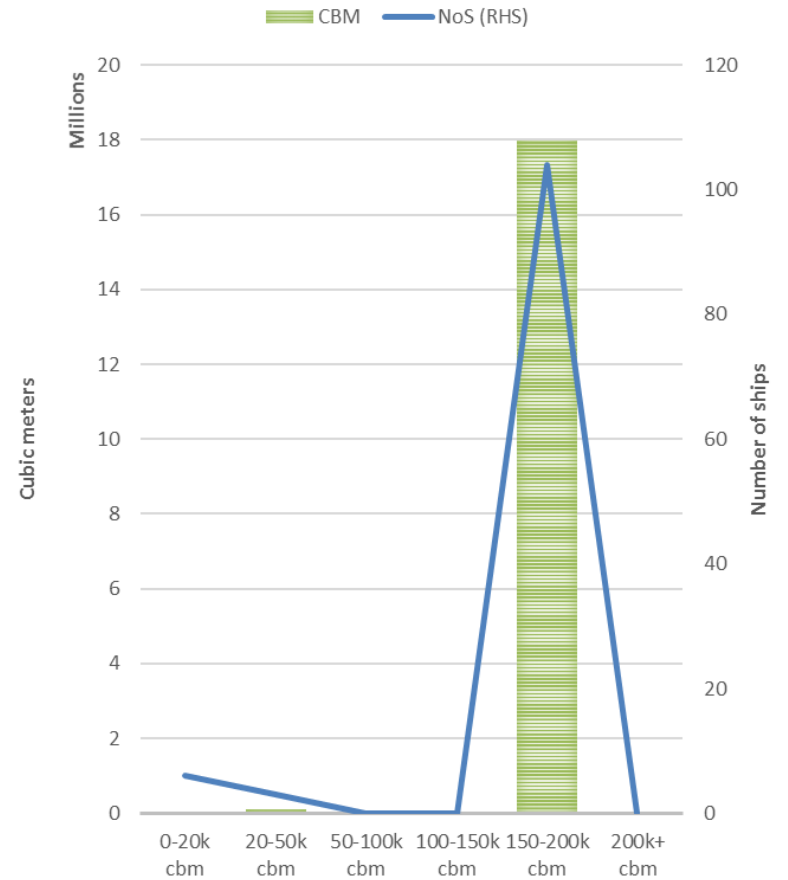

Containment system vs prime mover

LNG FLEET IN SERVICE CCS VS PRIME MOVER

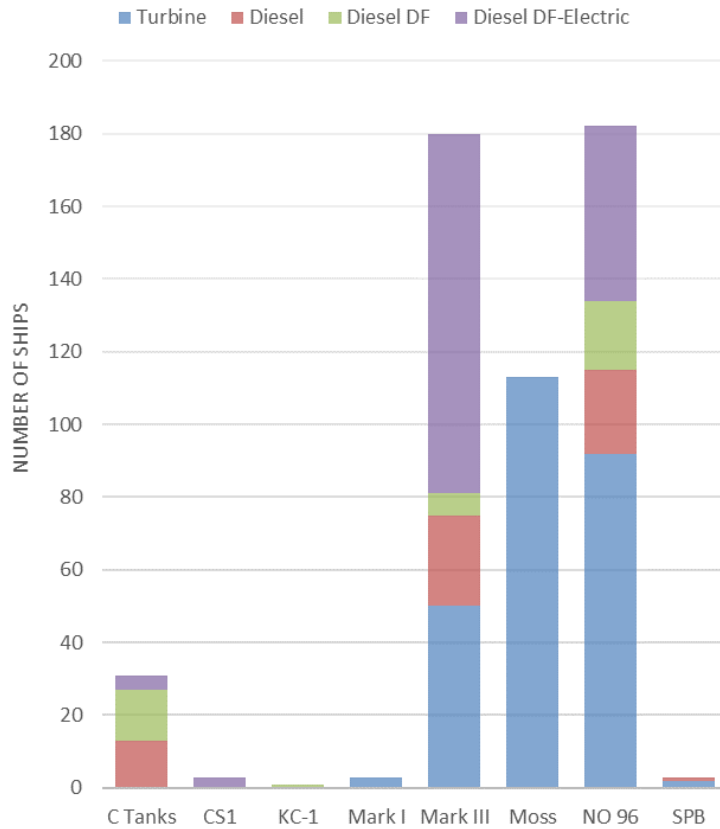

LNG FLEET ON ORDER CCS VS PRIME MOVER

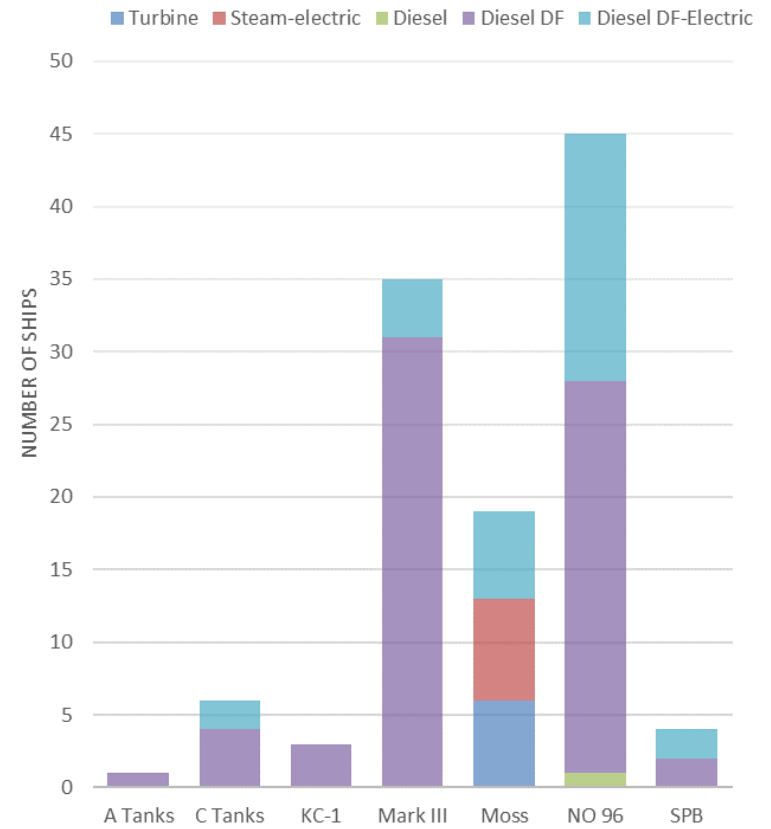

Two-stroke diesel (simplified)

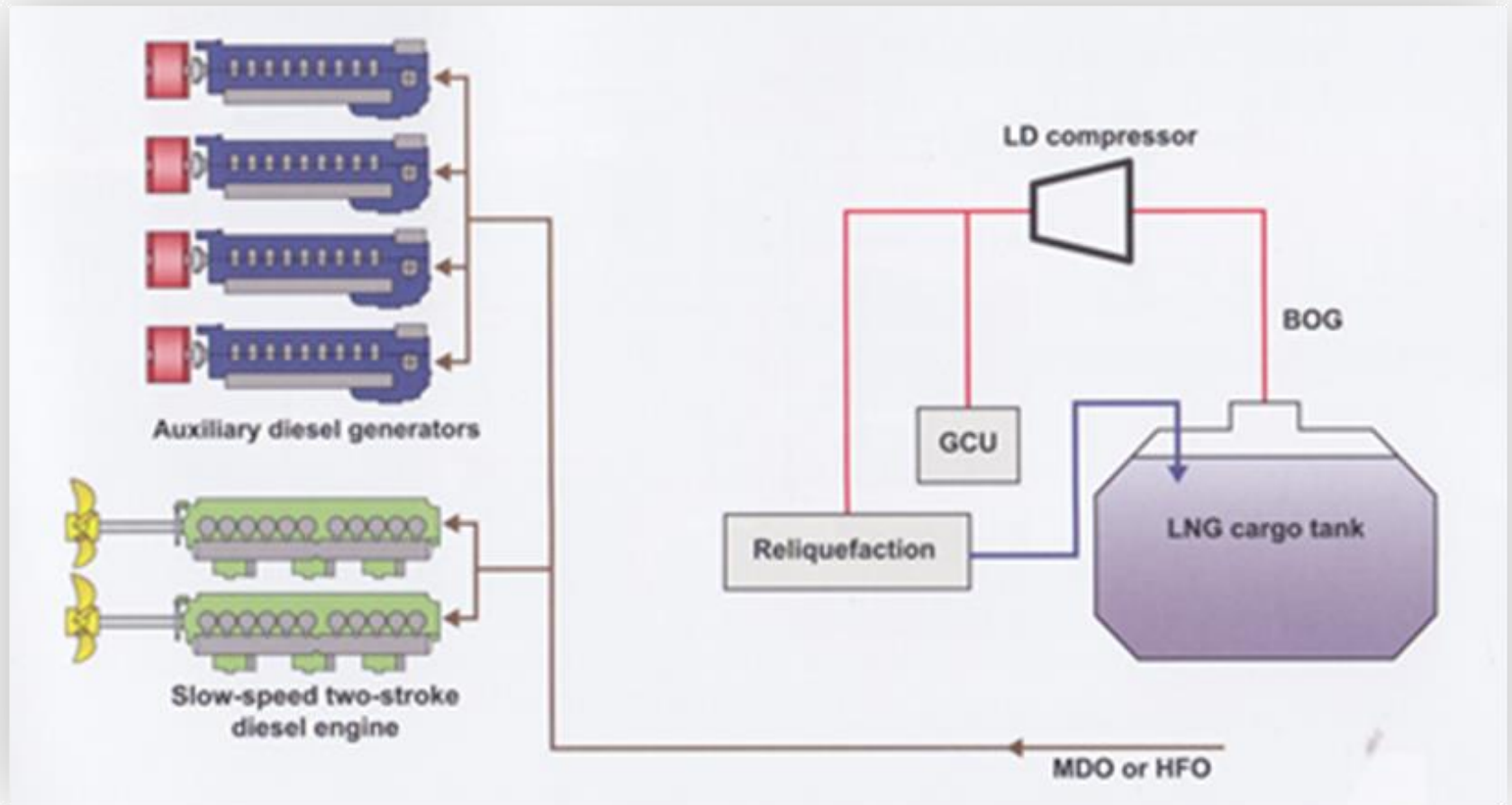

Diesel – electric (simplified)

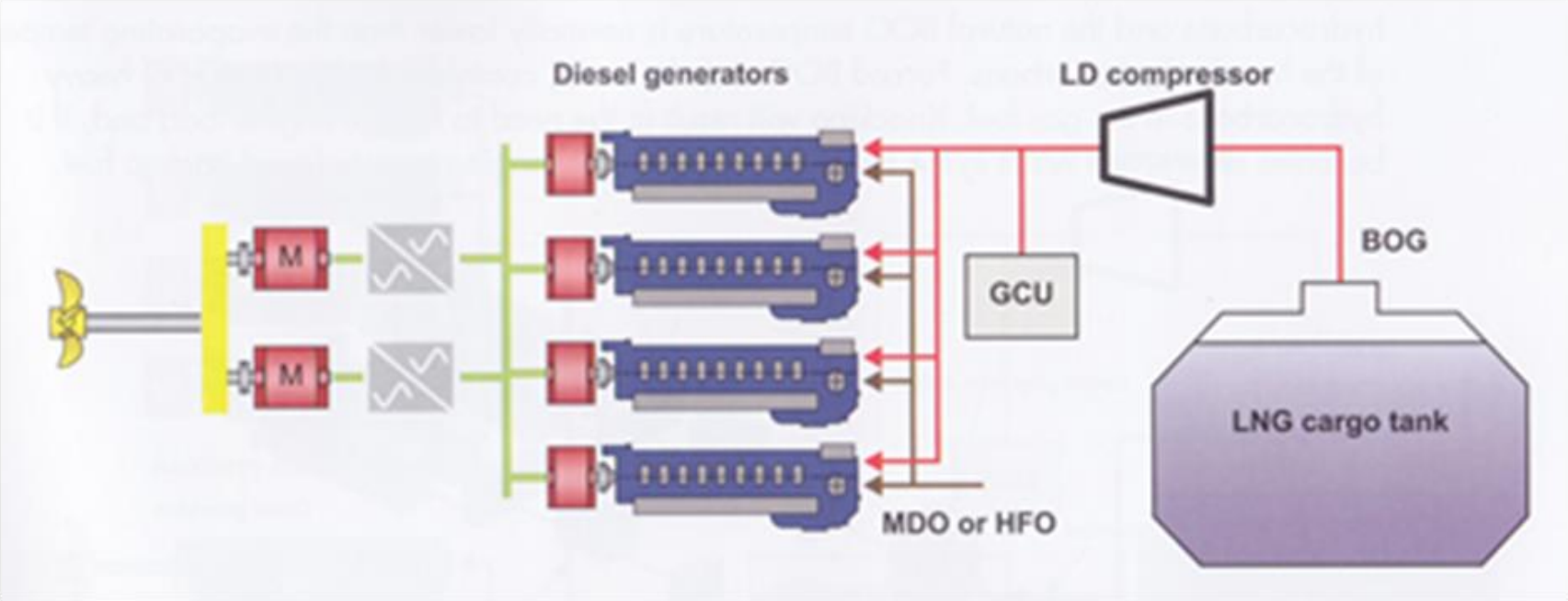

Conclusions

Arguably the most promising sector

LNG still regarded as environmental friendly

Very strong fundamentals

New tonnes and new miles! - redesign

More NB contracts – there is potential!

Thank You

Jakub Walenkiewicz
Jakub.Walenkiewicz@dnvgl.com

www.dnvgl.com

SAFER, SMARTER, GREENER